

> MULTISENSOR MS4R

Roombus



The Priva Multisensor MS4R combines the following sensors:

- presence detection (infrared measurement)
- light intensity
- temperature
- air humidity

Characteristics

- multiple sensors in compact housing
- various easy installation options
- various lenses for optimum presence detection
- two connection options
- immediately ready for use in a Roombus configuration

Multiple sensors in compact housing

Using a multisensor means you do not need to install individual sensors; a single multisensor is all that is required. This saves on the cost of the sensors themselves and on installation costs.

Various easy installation options

The multisensor can easily be mounted in or on a ceiling using mounting brackets. By default, the multisensor has a ring which makes the multisensor suitable for recessed ceiling mounting in a thin ceiling plate. With separately available accessories, the multisensor is suitable for recessed ceiling mounting using spring clamps or for ceiling surface mounting.

A different lens can be installed without disassembling the unit.

Various lenses for optimum presence detection

A lens set is available as an accessory. The detection range for presence detection is determined by the lens that has been installed. You can choose lenses that have been optimised for round or rectangular detection ranges of various dimensions. The right lens will ensure optimum presence detection for every room.

Two connection options

The multisensor can be connected via the Roombus connector (RJ45) or via a 4-pin plug-in screw connector.





Immediately ready for use in a Roombus configuration

Via the Roombus interface, the device can be immediately included in a Roombus configuration with a Comforte CX2 or Comforte CX2 VAV.

A Roombus device is set in such a way that it is immediately ready for use in a default Roombus configuration. If more than one instance of the same type is included in a Roombus configuration, the addresses must be changed so that each instance has a unique address. Thus, with more than one multisensor, the addresses must be changed so that each multisensor has a unique address. Change the address of a multisensor with the rotary switch and in TC Engineer.

Specifications

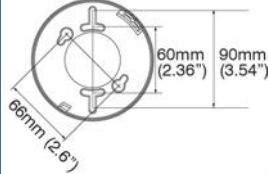
General	
Article	Priva Multisensor MS4R
Article number	111294
Dimensions	45 x diam. 79 mm (with standard lens)
Installation depth	23 mm
Mounting hole (for standard recessed ceiling mounting)	diam. 60 mm
Mounting hole (with recessed ceiling mounting with spring clamps)	diam. 70 mm
Weight	75 grams
Standard lens	type D diam. 12 m detection range at an installation height of 6 m other lenses are available separately in a lens set
Mounting options	<ul style="list-style-type: none"> standard recessed ceiling mounting <i>Requirements:</i> <ul style="list-style-type: none"> ceiling thickness > 10 mm ceiling at the rear side accessible for tightening of locking washer recessed ceiling mounting with spring clamps (MS4R-RM mounting bracket available as an accessory) ceiling surface mounting (MS4R-SM mounting bracket available as an accessory)
Indication	LED indication of movement

Article delivered as standard Accessories			
Priva Multisensor MS4R	MS4R-LS5 lens set	MS4R-SM mounting bracket	MS4R-RM mounting bracket
Article number 111294	Article number 111295	Article number 111296	Article number 111298
		 	

Standard recessed ceiling mounting	Ceiling surface mounting with MS4R-SM mounting bracket	Recessed ceiling mounting with MS4R-RM mounting bracket
Article number 111294	Article numbers 111294 and 111296	Article numbers 111294 and 111298
		



Electrical	
Input voltage	12 ... 24 VDC ± 10%
Supply current	11 mA at 16 VDC (power supply from the Comforte) 8 mA at 24 VDC (power from the Roombus power supply)
Maximum used power	< 0.5 W

Environment	
Permissible temperature during operation	0 ... 50°C
Permissible temperature during storage	-20 ... 60°C
Permissible air humidity during operation and storage	10 ... 95%

Measurements	
Presence detection	
Movement sensor	infra-red pyroelectric, omni-directional, 4 elements
Detection range	dependent on lens and installation height
Switch-on delay	adjustable from 0 ... 5 min, with a resolution of 1 s default setting: 0 s
Switch-off delay	adjustable from 5 s ... 30 min, with a resolution of 1 s default setting: 5 s
Detection rate	0.3 ... 3.0 m/s
Light intensity	
<i>Only to be used as a relative measurement, because the absolute value depends on the orientation and viewing angle of the sensor, and on the type of lens, and because the sensor only measures the light intensity of the ceiling.</i>	
Measurement range	1 ... 2000 Lux
Resolution	1 Lux
Measurement interval	adjustable from 2 ... 60 sec, with a resolution of 1 s default setting: 5 s
Temperature	
Measurement range	0 ... 50°C
Resolution	0.1°C
Accuracy	±0.5°C, with ceiling mounting, measured 20 cm below the sensor
Measurement interval	adjustable from 2 ... 60 sec, with a resolution of 1 s default setting: 5 s
Air humidity	
Measurement range	10 ... 95%
Resolution	0.1%
Accuracy	±4 % at 20 ... 80% relative air humidity ±5% at 10 ... 20% and 80 ... 95% relative air humidity
Measurement interval	adjustable from 2 ... 60 sec, with a resolution of 1 s default setting: 5 s

Connections	
Type of connector	<ul style="list-style-type: none"> 4-pin plug-in screw connector for power supply and Roombus (supplied) RJ45
Cable type	twisted pair, shielded or unshielded
Communication interface	RS-485
Communication protocol	Modbus RTU
Baud rate	115200 baud
Other parameters	number of data bits: 8 parity: even number of stop bits: 1
RS-485 port protection	protected against incorrect connection of ± 26.4 VDC
Cross section	0.08 – 1.5 mm ² (without ferrule connector) 0.08 – 0.5 mm ² (with ferrule connector)
Strip length / connector length	6 mm

Housing	
Material	UV stabilised
IP code	IP20 (IEC 60529)
Flammability class	UL94 V-0
Colour	cream (RAL 9001)
Type of device	open type of device: <ul style="list-style-type: none"> • for indoor use only • in environment with contamination level 2

Regulations and standards		
Europe		<ul style="list-style-type: none"> • Low Voltage Directive (2014/35/EU): <ul style="list-style-type: none"> • EN 60950-1 (information technology equipment) • EMC Directive 2014/30/EU: <ul style="list-style-type: none"> • EN 61000-6-2 (generic immunity standard) • EN 61000-6-3 (generic emission standard) • EN 61326-1 (measurement and control equipment) • EN 55011 (Industrial, scientific and medical equipment) • RoHS directive 2011/65/EU
		in compliance with WEEE directive 2012/19/EU

Connection specifications



Rear side of the multisensor with connections

Left: 4-pin plug-in screw connector

Right: RJ45 connector

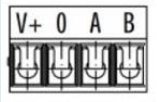
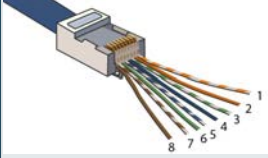
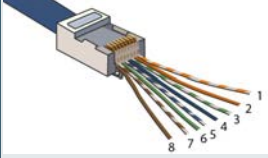
Description	Multisensor MS4R connectors		Roombus connector
	Plug-in screw connector	RJ45 connector	RJ45 connector
			
+ of power supply	V+	Pin 1 (orange/white)	Pin 1 (orange/white)
GND of power supply and RS485	0	Pin 2 (orange)	Pin 2 (orange)
RS485-A	A	Pin 3 (green/white)	Pin 3 (green/white)
RS485-B	B	Pin 6 (green)	Pin 6 (green)

Addressing



Front of the sensor with rotary switch

Addressing	
Structure of address	fixed address offset + adjustable address section
Fixed address offset	0
Adjustable address section (with rotary switch)	1 ... 8
Available address range	1 ... 8

Specifications of Multisensor MS4R lenses

The specifications of the Multisensor MS4R lenses are described in the *Lenses datasheet*. The datasheet includes specifications relating to installation height, detection range and detection patterns.

Priva (head office)
Zijlweg 3
2678 LC De Lier
The Netherlands

Your Priva partner:

See www.priva.com for contact information of a Priva office or partner for your region.

